



GUIDANCE NOTES
GD004-2025

ISClass

INTERNATIONAL SHIP CLASSIFICATION

**GUIDELINES FOR HULL
GIRDER ULTIMATE STRENGTH
ASSESSMENT OF CRUISE SHIP
BASED ON NONLINEAR FINITE
ELEMENT METHOD**

2025

Effective from 1 April 2025

CONTENTS

Chapter 1 General	1
1.1 General provisions.....	1
1.2 Symbols, terms and definitions.....	1
1.3 Scope of application	2
Chapter 2 Finite Element Modeling and Calculation	3
2.1 General provisions.....	3
2.2 Analysis models.....	4
2.3 Element types	6
2.4 Mesh quality and size	6
2.5 Material characteristics	7
2.6 Initial geometric imperfections of stiffened panels.....	7
2.7 Loads.....	10
2.8 Boundary conditions	13
2.9 Analysis steps of global model and local model.....	14
2.10 Extent of collision and grounding damage.....	15
2.11 Ultimate capacity calculation.....	16
Chapter 3 Hull Girder Ultimate Strength Check	18
3.1 General provisions.....	18
3.2 Hull girder ultimate strength criterion	18
3.3 Hull girder residual strength criterion.....	18
Appendix A Nonlinear Finite Element Methods and Usage Recommendations	20
A.1 General provisions.....	20
A.2 Iterative solution of load increment in nonlinear finite element.....	20
A.3 Selection of iterative algorithms	20
A.4 Selection of nonlinear analysis types	21
A.5 Load cases and restart analysis technologies	22

Chapter 1 General

1.1 General provisions

1.1.1 The Guidelines provides a nonlinear finite element method for hull girder ultimate strength assessment of cruise ship, and is applicable for assessing the global hull girder ultimate strength and the damaged (collision/grounding) hull girder residual strength. The general provisions and usage recommendations also apply to the ultimate strength calculation of other ship types or local stiffened panel structures.

1.1.2 A local model based on one frame spacing or cargo hold region may be used to calculate the hull girder ultimate strength and residual strength. When a local model is used, due consideration is to be given to the influence of structures outside the scope of the analysis model on the analysis results.

1.2 Symbols, terms and definitions

1.2.1 Structural nonlinearity: In finite element numerical analysis, the stiffness of a discretized structure is characterized by its stiffness matrix K . When the structure is in a static equilibrium, K relates the external nodal load vector f to the nodal displacement vector u , which can be expressed as $f = Ku$. When the stiffness of a structure changes with the load, the structure is called a nonlinear structure. The sources of nonlinearity include material nonlinearity, boundary nonlinearity and geometric nonlinearity.

1.2.2 Material nonlinearity: At high strains, the material yields and some strains cannot be recovered, resulting in a nonlinear relationship between load and response.

1.2.3 Boundary nonlinearity: When the boundary conditions change during the analysis process, such as impact, contact, etc., boundary nonlinearity arises.

1.2.4 Geometric nonlinearity: Geometric nonlinearity occurs in structures such as girders and shells with large displacements and large angles. Large deformations cause changes in the shape of the structure, resulting in applied load effects and structural stiffness that vary with the instantaneous geometric shape of the structure.

1.2.5 Incremental iteration solution: The effective method for solving nonlinear systems and tracking equilibrium paths is the incremental iteration method, which decomposes the total load into a series of smaller incremental steps. For each load increment, multiple iterations are performed to converge and find the displacement increment of the corresponding load increment step within the numerical tolerance range. One or more linear analyses in the load step are to be used to approximate the nonlinear relationship between the applied load and displacement.

1.2.6 Load-displacement curve: When analyzing the ultimate capacity of various structures, the relationship between the loads acting on the structure and the appropriately selected structural deflection is usually plotted. This type of curve is usually referred to as the load-displacement/shortening ($P - \Delta$) curve. The $P - \Delta$ curve of the vertical bending moment and angle θ of a typical hull girder is shown in Figure 1.2.6.

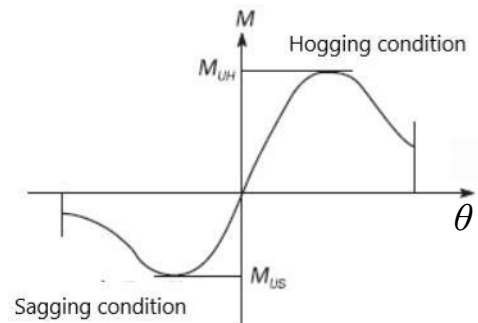

Figure 1.2.6 Hull girder vertical bending moment versus curvature

1.2.7 Coordinate system

The right-handed coordinate system is used in the Guidelines, with the following requirements:

- (1) X-axis: longitudinal axis of hull, positive forward;
- (2) Y-axis: transverse axis of hull, positive to port;
- (3) Z-axis: vertical axis of hull, positive upwards;
- (4) Origin: the intersection of the longitudinal section of the ship, the aft end of the ship length L and the baseline.

1.3 The following drawings and technical documents are to be submitted:

- (1) Drawings/information and lists to be used;
- (2) Analysis and calculation reports and necessary electronic data files, including:
 - ① Introduction to the finite element software to be used;
 - ② A graphical or detailed description of the finite element structural model and its related properties, including coordinate system, extent of model, element type, mesh size, number of nodes, number of elements, etc;
 - ③ Detailed description of material properties, initial geometric imperfections and boundary conditions;
 - ④ Detailed description of lateral loads (if applicable);
 - ⑤ Detailed description of the failure sequence of hull girder members;
 - ⑥ Detailed description of the assumed extent of collision and grounding damages;
 - ⑦ Deformation and stress contour of the structural model at the limit state and after collapse failure (based on Von Mises stress criterion);
 - ⑧ Load -displacement curve of the middle section of the hull girder is to include a significant load drop.

Chapter 2 Finite Element Modeling and Calculation

2.1 General provisions

2.1.1 The nonlinear finite element method for hull girder ultimate strength is to take the following factors into consideration:

- (1) Geometric nonlinearity characteristics;
- (2) Material nonlinearity characteristics;
- (3) Initial imperfections (geometric imperfections of panels and stiffeners);
- (4) The loads acting synchronously are to include:
 - ① External hydrostatic pressure and seawater dynamic pressure
 - ② Hull girder shear force;
 - ③ Hull girder bending moment;
- (5) Boundary conditions;
- (6) The mutual influence between buckling modes;
- (7) The interaction between structural members (such as panels, stiffeners, girders, etc.);
- (8) Post buckling capacity;
- (9) Permanent/buckling damage of the structure caused by compression overload in the hull girder (double bottom effect or similar conditions).

2.1.2 The hull girder ultimate strength assessment is carried out based on the net scantling of the hull structural members, and applied corrosion addition is to be taken as 0.5 times the value specified in Table 2.2.7.2 of Chapter 2, Section 2 of the ISC Rules for Cruise Ships.

2.1.3 A finite element model is to be established based on the mid-surface dimensions of the panels and stiffeners. As shown in Figure 2.1.3, the equivalent formula for the dimensions of the stiffener are:

$$h' = h + t_f + t_p$$

$$b' = b_f + t_w$$

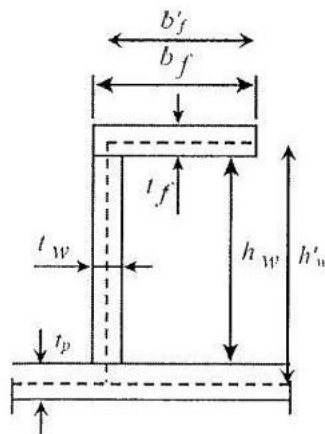

Figure 2.1.3 Equivalent dimension of stiffeners

2.1.4 Bulb profile can be modeled as an equivalent combination of cross-sections, as shown in Figure 2.1.3:

$$h_w = h'_w - \frac{h'_w}{9.2} + 2$$

$$b_f = \alpha \left(t'_w + \frac{h'_w}{6.7} - 2 \right)$$

$$t_f = \frac{h'_w}{9.2} - 2$$

$$t_w = t'_w$$

Where: h'_w , t'_w — net height and net thickness of bulb profile, in mm, shown as 2.1.4;

a — coefficient, taken as:

$$\alpha = 1.1 + \frac{(120 - h'_w)^2}{3000} \quad \text{for } h'_w \leq 120,$$

$$\alpha = 1.0 \quad \text{for } h'_w > 120,$$

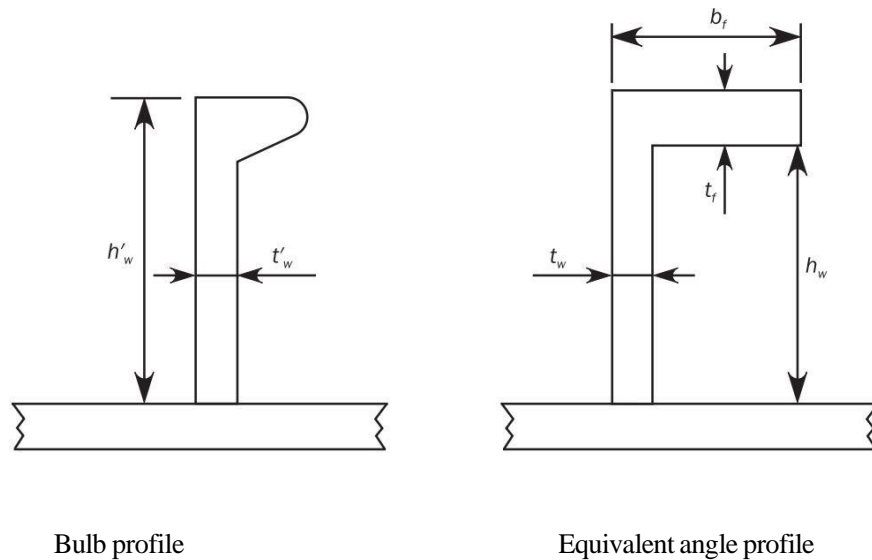

Figure 2.1. 4 Equivalent dimension of bulb profile

2.2 Analysis models

2.2.1 The ultimate strength calculation model includes a global model and a local model.

2.2.2 The global model adopts linear elastic analysis to provide boundary conditions for local analysis models. It is recommended to use a complete ship structural model for the global model, as shown in Figure 2.2.2. If the hull structure has continuous transverse bulkheads in the area between the bottom and the top deck, the longitudinal direction of the global model can also be taken between two transverse bulkheads (including the transverse bulkheads), the transverse direction can be taken as the entire width of the ship, and the vertical direction can be taken as the extent between the shell bottom plate and the top deck.

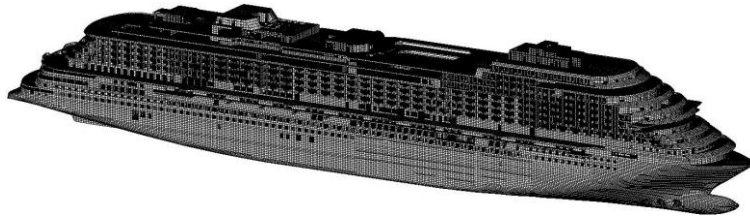

Figure 2.2.2 Example of global model

2.2.3 The local model is a nonlinear finite element analysis model for the areas concerned:

(1) For the hull girder ultimate strength analysis in an intact state, the longitudinal extent of the local model is to be taken as at least one transverse frame spacing (the front and rear ends of the model are transverse web frames, and the transverse web frame structures at the front and rear ends do not need to be included in the local model), the transverse extent is to be taken as the entire width of the ship, and the vertical extent is to be taken as the range between the shell bottom plate and the top deck, as shown in Figure 2.2.3.

(2) For the hull girder residual strength analysis in a damaged state, the longitudinal extent of the local model is to cover at least the damaged area and extend a web frame spacing towards the front and rear ends (the front and rear ends of the model are transverse web frames, and the transverse web frame structures at the front and rear ends do not need to be included in the local model). The transverse extent is to be taken as the entire width of the ship, and the vertical extent is to be taken as the range between the shell bottom plate and the top deck.

(3) The local model is to include all longitudinal continuous structural members, transverse structural members and local stiffeners within the extent of model.

(4) The extent of model can be reduced based on the symmetry of the structure and load. For example, if the structural model is symmetrical on both sides, and the load is also symmetrical on both sides, the extent of model from the mid longitudinal section to any side can be selected for calculation.

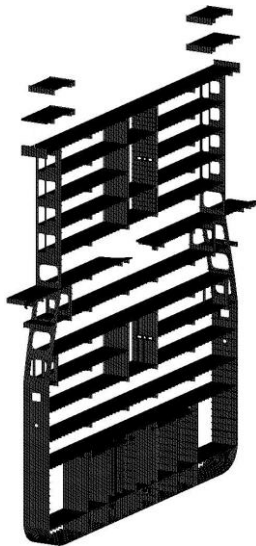

Figure 2.2.3 Example of local model for hull girder ultimate strength analysis in an intact state

2.2.4 The finite element model is to take into account the manholes and lightening holes of the hull structure.

(1) The openings in global model can be modeled by deducting elements, and openings with a height less than half of the web height can be omitted.

(2) The manholes and continuous lightening holes on the longitudinal structural members of the local model are to be modeled according to the actual shape and size.

2.3 Element types

2.3.1 The plate and primary supporting members are to use 4-node shell elements. The web adopts a 4-node shell elements, and the stiffeners on the wing plate and the main supporting members can be simulated by line elements.

2.4 Mesh quality and size

2.4.1 The mesh size of the global model is to meet the following requirements:

(1) One element between each adjacent longitudinal. In the longitudinal direction, the length of each element is not to exceed twice the longitudinal spacing, and at least three elements between the primary supporting members;

(2) One element between each adjacent frames on the transverse bulkhead.

(3) One element between each adjacent web stiffener of transverse web frame, cross ties and horizontal girder;

(4) At least three elements over the depth of double bottom girder, bottom floor, transverse web frame, vertical web frame and transverse bulkhead horizontal girder;

(5) The aspect ratio of the element is generally to be less than 3.

2.4.2 The mesh size of the local nonlinear analysis model is to meet the following requirements:

(1) Plate: 6-8 elements between two adjacent stiffeners;

(2) web plate : 3-6 elements along the height direction of web;

(3) Face plate: if the shell element is used, one element along the width direction of angle and bulb profile, and two elements along the width direction of face plate of T bar;

(4) Web of primary supporting member: if stiffener is provided on web, 3 elements on the webs between the stiffeners; if stiffener is not provided on the web, 6 elements on the webs;

(5) Face plate of primary supporting member: at least 4 elements along the width direction of face plate;

(6) The refined analysis model is to be meshed according to the requirements of (1) - (5), and the mesh size is also to be ensured not greater than 50mm × 50mm.

2.4.3 The mesh quality of local nonlinear finite element analysis is to meet the following requirements:

(1) Aspect ratio of element: the ratio of the longest side to the shortest side of an element is close to 1;

(2) Skewness angle: difference between the right angle and the smallest angle between intersecting element mid-lines is generally to be less than 30 degrees;

(3) Warping angle: a parameter indicating distortion outside the plane of plate element, is generally to be less than 5 degrees;

(4) Element corner angle:: is generally to be greater than 45 degrees, but less than 135 degrees;

(5) Jacobian, representing the deviation between an element and an ideal shape, is generally to be greater than 0.6;

(6) Triangular element is to be avoided to use as much as possible.

2.5 Material characteristics

2.5.1 For the calculation of the hull girder ultimate capacity, it is recommended to use material models with bilinear and isotropic hardening characteristics. The bilinear stress-strain curve of the material is shown in Figure 2.5.1, with the following specific parameters:

- (1) Elastic modulus $E=206000$ N/mm²;
- (2) Modulus after yielding $ET=1000$ N/mm²;
- (3) Poisson's ratio $\nu=0.3$;
- (4) Yield strength ReH .

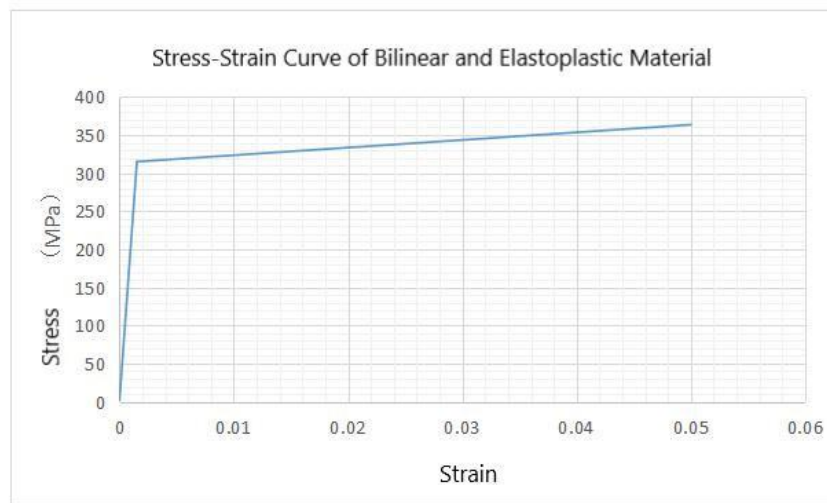

Figure 2.5.1 Schematic diagram of stress-strain curve of material

2.6 Initial geometric imperfections of stiffened panels

2.6.1 Initial imperfections, such as geometric defects (such as nonuniformities in shape, eccentricities, and local imperfections) and residual stresses may rise in the process of ship construction. The shape and size of initial imperfections have a significant impact on the ultimate capacity and buckling mode of structures that are sensitive to initial imperfections. The typical stiffened plate and its geometric parameters are shown in Figure 2.6.1, where:

- spacing of web frame, in mm;
- width of stiffened plate, in mm;
- spacing of longitudinals, in mm;
- h — height of web, in mm.

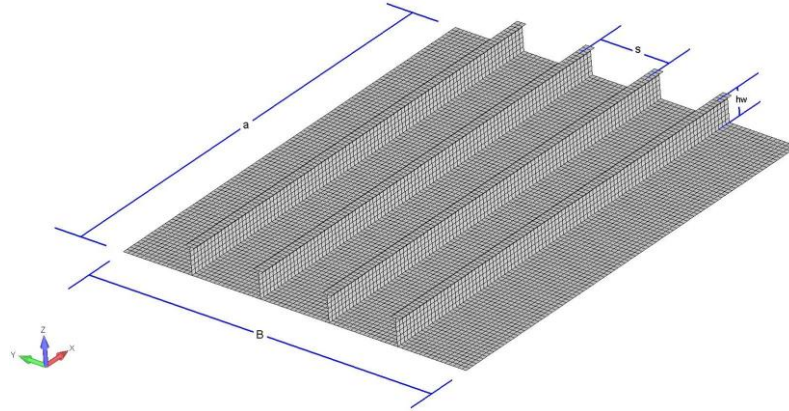

Figure 2.6.1 Schematic diagram of typical stiffened plate and its geometric parameters

2.6.2 Initial imperfections are usually applied to parts of the structure that are prone to buckling. For the hull girder ultimate strength assessment, initial imperfections are to be applied to the deck structure under the sagging condition, and initial imperfections are to be applied to the bottom structure under the hogging condition.

2.6.3 The initial imperfections is only to be applied to the local nonlinear model.

2.6.4 According to different structural members, initial defects include the following different levels:

- (1) The global imperfections of stiffened panel (plates and stiffeners) between the web frames;
- (2) The local imperfections of plates between stiffeners;
- (3) The local imperfections of stiffened webs;
- (4) The local tripping imperfections of stiffeners.

2.6.5 In general, the initial imperfections can be treated by the following different methods:

- (1) Directly applying the measured initial imperfections to the finite element model through offset node is the most accurate method for treating geometric imperfections;
- (2) The buckling modes obtained from the analysis of buckling eigenvalues are linearly superimposed on the finite element model, as shown in 2.6.6;
- (3) Applying initial imperfections directly on the nodes of the finite element model, see 2.6.7.

2.6.6 Buckling mode superposition method is firstly to carry out linear buckling eigenvalue analysis, select the buckling modes corresponding to the 4 different imperfections in 2.6.4 according to the consistent mode method, scale and superimpose the global buckling mode and local buckling mode to obtain the initial imperfections required for calculation. Corresponding boundary conditions are to be applied during buckling mode calculation to obtain the true buckling mode.

2.6.7 The method of directly applying initial imperfections in 2.6.1 is based on the imperfections pattern of trigonometric functions, which describes the initial imperfections by offsetting structural nodes. Imperfections are given as vertical displacements in the the z-axis direction of nodes in the local coordinates of the plate element. The initial imperfections at different levels are described in 2.6.4 and calculated according to the following formula.

(1) The global imperfections of the stiffened plate between web frames is shown in Figure 2.6.7.1:

$$W_{SP} = \frac{a}{1000} \sin \frac{\pi x}{a} \sin \frac{\pi y}{B}$$

(2) The local imperfections of the plate is shown in Figure 2.6.7.2:

$$W_p = \frac{s}{200} \sin \frac{m\pi x}{a} \sin \frac{\pi y}{s}$$

(3) The local imperfections of stiffened web is shown in Figure 2.6.7.3:

$$W_{web} = \frac{h_w}{200} \sin \frac{m\pi x}{a} \sin \frac{\pi y}{h_w}$$

(4) The tripping imperfections of stiffeners is shown in Figure 2.6.7.4:

$$W_{Trip} = \frac{a}{1000} \frac{y}{h_w} \sin \frac{\pi x}{a}$$

(5) Overlaying the imperfections in (1) - (4) above to obtain the initial imperfections of the stiffened plate, as shown in Figure 2.6.7.5.

Where:

m — the number of buckling modes of the plate, taking the smallest integer satisfying the equation $a/s \leq \sqrt{m(m+1)}$;

x, y — The local coordinate of the plate, x is the value along the longitudinal direction of the stiffened plate or stiffener, and y is the value along the transverse direction of the stiffened plate or the height direction of the stiffener.

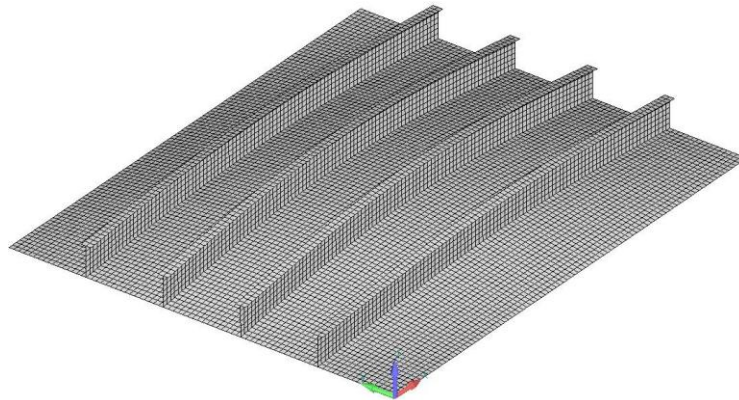

Figure 2.6.7.1 Schematic diagram of global imperfections of stiffened plates between web frames

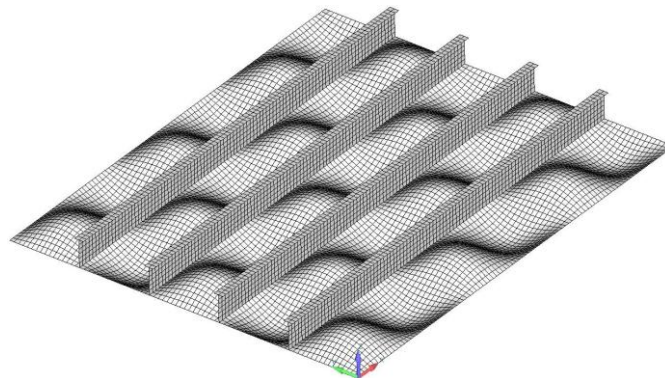

Figure 2.6.7.2 Schematic diagram of local imperfections of plate

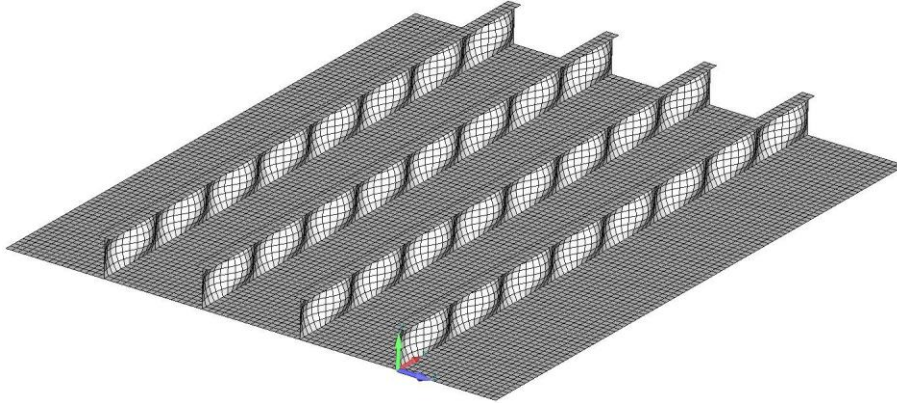

Figure 2.6.7.3 Schematic diagram of local imperfections of stiffened web

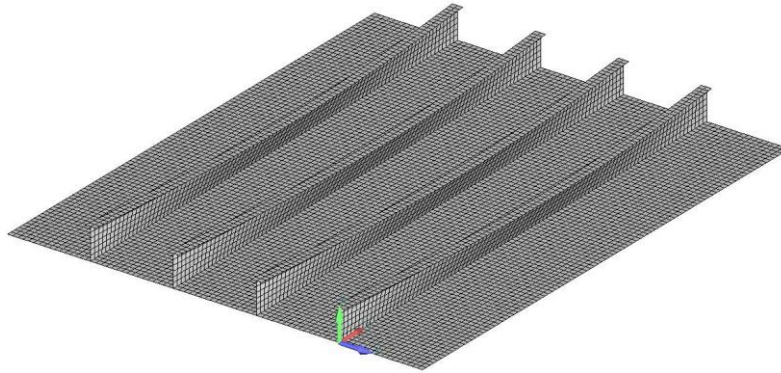

Figure 2.6.7.4 Schematic diagram of tripping imperfections of stiffeners

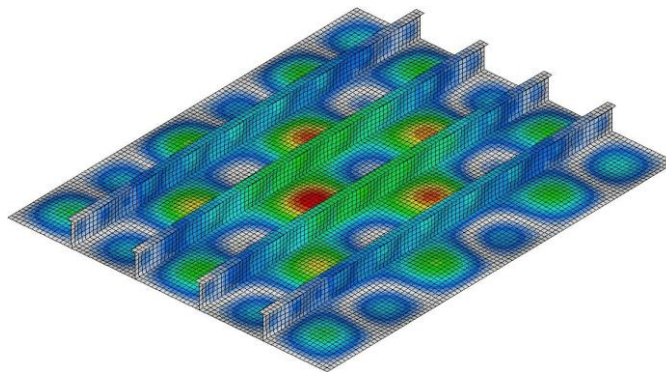

Figure 2.6.7.5 Schematic diagram of combined imperfections of stiffened plate

2.7 Loads

2.7.1 The load includes global load (hull girder load) and local load.

2.7.2 The global load includes the shear force and bending moment of the hull girders. By applying wave pressure and distributed nodal forces on the global model, the target value of the hull girder load is achieved within the target area of nonlinear analysis. The hull girder load can be

applied according to the ISC Guidelines for Complete Ship Model Calculation of Cruise Ships, or other equivalent methods (such as direct calculation of hydrodynamic loads) can be used. If the global analysis adopts a local cargo hold model, local loads can be applied and the hull girder loads can be adjusted according to the relevant requirements of Chapter 1, Section 5 of Volume 2 of the ISC Rules for Classification of Sea-going Steel Ships.

2.7.3 In the nonlinear calculation process of the hull girder ultimate capacity, the loads on the hull girder are to be gradually increased until the hull girder reaches its ultimate capacity.

2.7.4 The local loads that need to be applied on the local nonlinear model are mainly the external sea pressure, including hydrostatic pressure (see 2.7.5) and seawater dynamic pressure (see 2.7.6). The local load on the local model remains unchanged in nonlinear calculations, i.e.: the local loads do not gradually increase with hull girder loads.

2.7.5 The external hydrostatic pressure p_s , in kN/mm^2 , at any point is calculated according to the following formula, and its distribution is shown in Figure 2.7.5.

$$p_s = \rho g(T_{LC} - Z) \quad \text{for } Z \leq T_{LC}$$

$$p_s = 0 \quad \text{for } Z > T_{LC}$$

Where: T_{LC} —midship draught under the considered loading conditions, in m;

ρ —density of seawater, taken as 1.025t/m^3 ;

Z —vertical distance from the calculating point to baseline, in m.

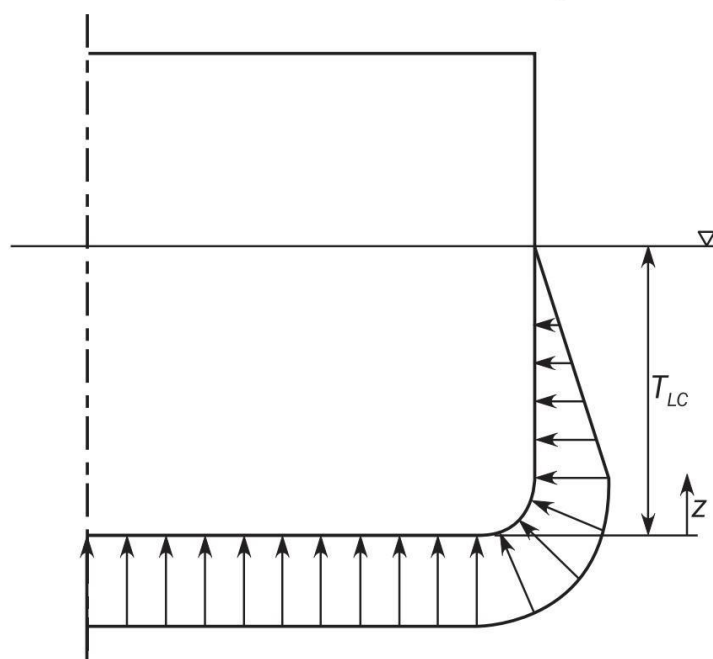

Figure 2.7.5 Schematic diagram of hydrostatic pressure,

2.7.6 Seawater dynamic pressure

(1) The seawater dynamic pressure, in kN/mm^2 , at the waterline of ship sides, is to be calculated by the following formula:

$$P_{WL} = 2B^{0.66} + 3CC_b + 0.4T_{LC}$$

Where: B —ship width, in m;

C_b —block coefficient;

C——coefficient, see 2.2.3.1, Section 2, Chapter 2, PART TWO of ISC Rules for Classification of Sea-going Steel Ships;

(2) The seawater dynamic pressure, P_{WL} , in kN/mm^2 , at the bottom edges (bilge), is to be calculated by the following formula:

$$P_{BS} = P_{WL} - 1.2T_{LC}$$

Where: P_{WL} , T_{LC} —— see (1).

(3) The seawater dynamic pressure, P_{BC} , in kN/mm^2 , at the centerline of bottom, is to be calculated by the following formula:

$$P_{BC} = 0.5(P_{WL} - 1.2T_{LC})$$

Where: P_{WL} , T_{LC} —— see (1).

(4) The seawater dynamic pressure, p_W , in kN/mm^2 , at any point under the waterline, is to be calculated by the following formula:

$$p_W = P_{WL} + (P_{BS} + P_{WL})\left(1 - \frac{Z}{T_{LC}}\right) + (P_{BC} - P_{BS})\left(1 - \frac{2Y}{B}\right)$$

Where: P_{WL} —— calculated according to (1)

P_{BS} —— calculated according to (2);

P_{BC} —— calculated according to (3);

B —— ship width, in m;

T_{LC} —— draught under the calculating condition, in m;

Y —— transverse distance from calculating point to longitudinal section, in m;

Z —— vertical distance from calculating point to baseline, in m.

(5) The seawater dynamic pressure, P_{hd} , in kN/mm^2 , at any point of side shell plate above the waterline, is to be calculated by the following formula:

$$P_{hd} = P_{WL} - 10(Z - T_{LC}) \quad \text{for } T_{LC} < Z \leq T_{LC} + \frac{P_{WL}}{10}$$

$$P_{hd} = 0 \quad \text{for } T_{LC} + \frac{P_{WL}}{10} < Z$$

Where: P_{WL} —— calculated according to (1);

T_{LC} —— draught under the calculating condition, in m;

Z —— vertical distance from the calculating point to baseline, in m.

(6) The load of green water on weather deck, P_{wdk} , in kN/mm^2 , is to be calculated by the following formula, but not less than 0:

$$P_{wdk} = P_{WL} - 10(Z_{dk} - T_{LC})$$

Where: P_{WL} —— calculated according to (1);

T_{LC} —— draught under the calculating condition, in m;

Z_{dk} —— vertical distance from weather deck to baseline, in m,

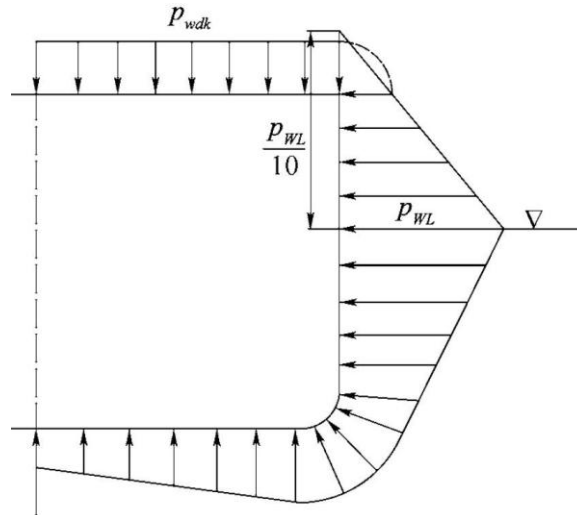

Figure 2.7.6 Schematic diagram of external seawater dynamic pressure

2.8 Boundary conditions

2.8.1 For the global analysis using complete ship model, the boundary condition is to eliminate rigid body displacement and is shown in Figure 2.8.1, as follows:

- (1) The plate keel at the bottom of the ship constrains the Y-direction displacement at the stem (point 1 in Figure 2.8.1), i.e.: $\delta_y = 0$;
- (2) The bow (point 2 in Figure 2.8.1) constrains the line displacement in 3 directions, i.e.: $\delta_x = \delta_y = \delta_z = 0$;
- (3) The nodes at both ends of the intersection line between the bulkhead deck and the transom plate (points 3 and 4 in Figure 2.8.1) constrain the Z-direction displacement, i.e.: $\delta_z = 0$.

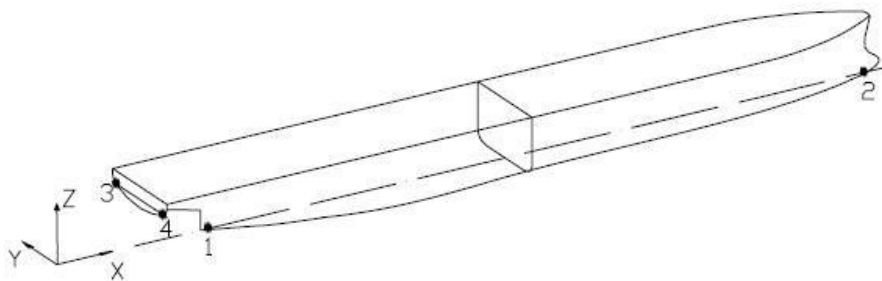

Figure 2.8.1 Schematic diagram of boundary conditions for complete ship model

2.8.2 If a local cargo hold model is used for global analysis, the following boundary conditions are to be adopted, as shown in Table 2.8.2.

- (1) Create independent points A and B at the intersection of the neutral axis in the cross-sections at both ends of the model;
- (2) Two independent points are associated with the displacements in the x, y, and z directions of the fore and aft end nodes of the model, as well as the rotation angle around the y-axis, using MPC elements;
- (3) Constrain the translation displacement in x, y, and z-direction and rotation around the x-axis of independent point A, and constrain the translation displacement in y and z-direction of independent point B.

Boundary conditions of local compartment FE model

Table 2.8.2

Displacement	Displacement constraint			Rotation constraint		
End A	Link	Link	Link	-	Link	-
End B	Same as the end A					
Independent point A	Cons.	Cons.	Cons.	Cons.	-	-
Independent point B	-	Cons.	Cons.	-	-	-

Notes: ① Cons.—— means the displacement constraint;

② Link—— the end nodes are linked to the degrees of freedom of independent points.

2.9 Analysis steps of global model and local model

2.9.1 Linear static analysis is to be carried out for the global model, the stiffness and load of the global model are to be condensed onto the interface nodes between the global model and the local model, and the nodal stiffness and load are to be applied to the corresponding nodes of the local model.

2.9.2 Where no grid transition is at the interface between the local model and the global model, constraint equations are used at the interface of the local model to establish linear displacement constraint relationships between nodes on the boundary that do not match the global model and the adjacent matching nodes, ensuring consistency of nodal displacement at the interface.

2.9.3 Nonlinear analysis of the local nonlinear model under global and local loads is to be calculated by taking consideration of the material nonlinearity and geometric nonlinearity. In the process of calculation, the local load is to be constant and gradually increase the global load until it reaches the hull girder ultimate capacity.

2.9.4 The calculation and analysis process of the global model and local model is shown in Figure 2.9.4.

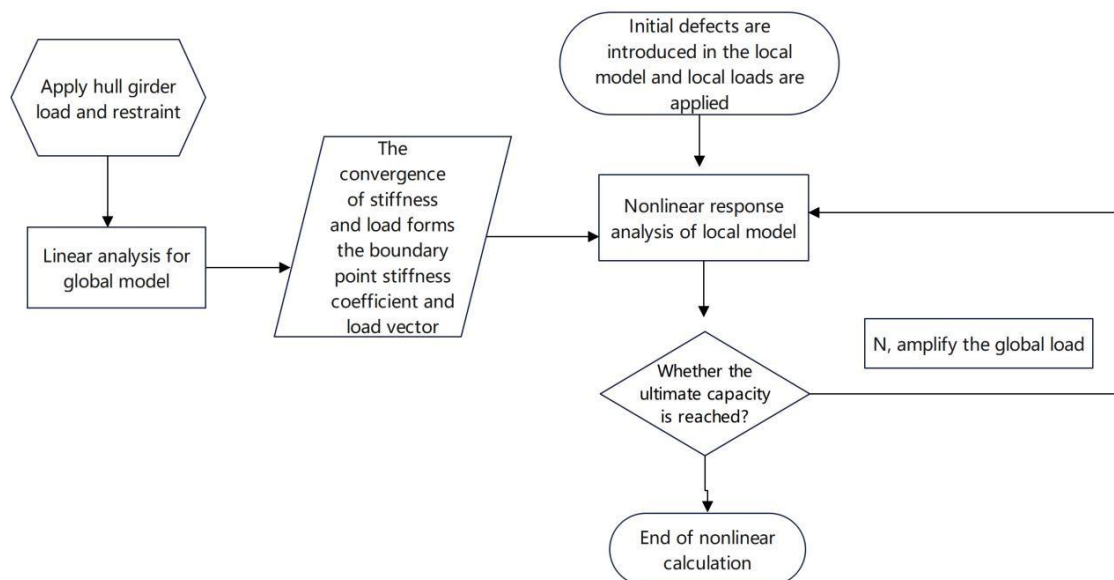

Figure 2.9.4 Calculation process of ultimate capacity

2.10 Extent of collision and grounding damage

2.10.1 The extent of collision damage is specified in 2.10.4, and the extent of grounding damage is specified in 2.10.5.

2.10.2 When the distance from the inner bottom and inner shell longitudinal bulkhead to the hull shell plate is greater than the extent of damage, the inner bottom plate and inner shell bulkhead plate and their attached frames are to be retained in the finite element model.

2.10.3 When the connection between the stiffener and the plate is not within the extent of damage, the stiffener element is to be retained in the finite element model.

2.10.4 For the collision damage assessment on the considered cross-section, the damage is on one side of the ship, the extent of damage is shown in Table 2.10.4 and the schematic diagram is shown in Figure 2.10.4.

Extent of collision damage in the model

Table 2.10.4

Extent of damage	Single hull	Double hull
Height, h	0.75D	0.60D
Depth, d	B/16	B/16
Length, l	Spacing of web frame	Spacing of web frame

Note : ① The extent of damage in the height direction is measured downwards 1 m from the upper edge of the strength deck. The definition of the strength deck of a cruise ship is specified in the ISC Rules for Cruise Ships.

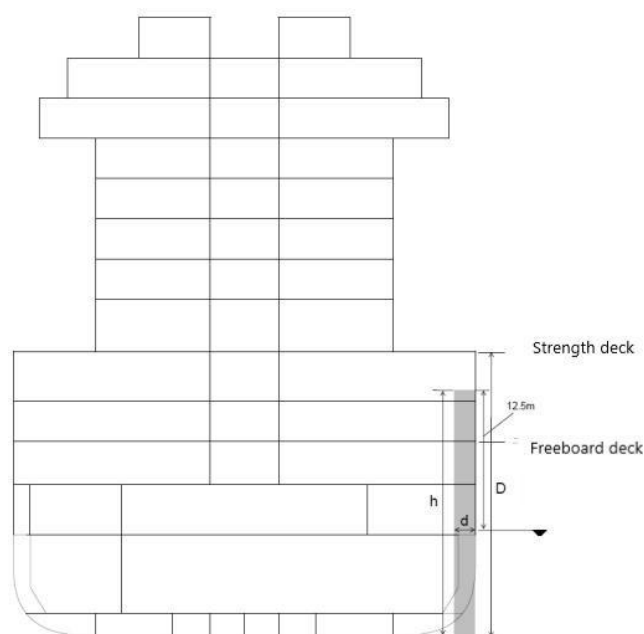

Figure 2.10.4 Schematic diagram of collision damage

2.10.5 For the grounding damage assessment on the considered cross-section, the damage is at the most unfavorable lateral position on the bottom of the ship, the extent of damage is shown in Table 2.10.5 and the schematic diagram is shown in Figure 2.10.5.

Extent of grounding damage in the model

Table 2.10.5

Extent of damage in height direction, h	$B/20$ and 2m, whichever is the less
Extent of damage in width direction, b	$0.60B$
Extent of damage in length direction, l	Spacing of web frame

Note: ① The extent of damage in the height direction is measured from the baseline of ship.

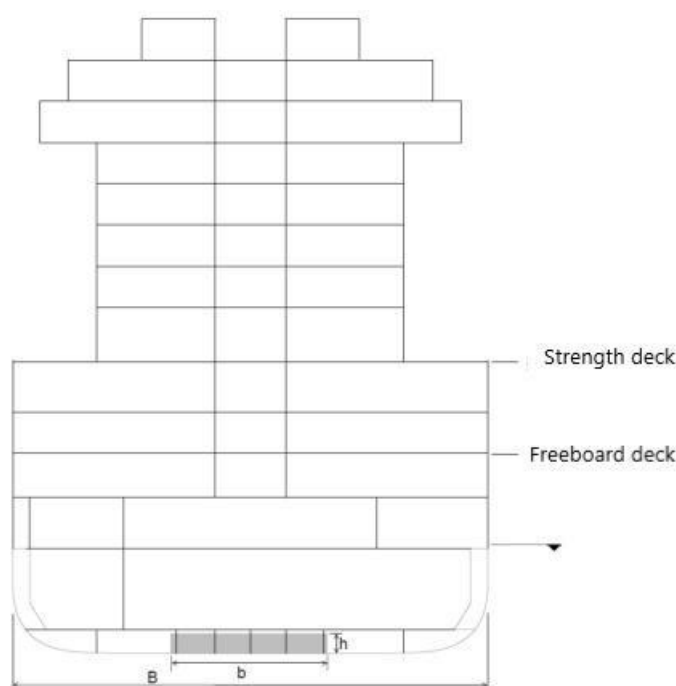

Figure 2.10.5 Schematic diagram of grounding damage

2.10.6 The extent of damage caused by collision or grounding can also be proposed by the shipowner/designer and approved by ISC.

2.11 Ultimate capacity calculation

2.11.1 Lateral load is to be applied on the local model and kept constant, and then hull girder load is to be gradually increased. When the load-displacement curve reaches the extreme point and the compressed structure has significant failure deformation, the bending moment at this extreme point is the ultimate capacity of hull girder .

2.11.2 The local model deducts the structural members within the extent of collision or

grounding damage stipulated in 2.10, and the extreme point bending moment calculated according to 2.11.1 is the residual ultimate capacity of the hull girder.

Chapter 3 Hull Girder Ultimate Strength Check

3.1 General provisions

3.1.1 This Chapter provides the hull girder ultimate strength check methods, including the followings:

- (1) The hull girder ultimate strength under an intact state of navigation conditions is shown in 3.2;
- (2) The hull girder residual strength under a damage state (collision/grounding) of navigation conditions is shown in 3.3.

3.1.2 The hull girder ultimate capacity means the maximum bending moment M_{UH} (hogging) and M_{US} (sagging) of the vertical bending moment M of the hull girder and the section angle θ curve, as shown in Figure 1.2.3.

3.2 Hull girder ultimate strength criterion

3.2.1 The ultimate capacity of any cross-section of the hull girder is to meet the following criteria:

$$\gamma_S M_S + \gamma_W M_W \leq \frac{M_U}{\gamma_R}$$

Where:

M_S —— Allowable hydrostatic bending moment for calculated cross-section of hull girders, in kN-m, see 2.2.2, Chapter 2 of CCS Rules for Cruise Ships;

M_W —— Wave bending moment for calculated cross-section of hull girder, in kN-m, see 2.2.3, Chapter 2 of CCS Rules for Cruise Ship;

M_U —— Ultimate capacity for calculated cross-section of hull girder, in kN-m, according to Chapter 2 of the Guidelines;

γ_S —— Partial safety factor of hydrostatic bending moment, $\gamma_S = 1.0$;

γ_W —— Partial safety factor of wave bending moment, $\gamma_W = 1.2$;

γ_R —— Partial safety factor of hull girder ultimate bending capacity $\gamma_R = \gamma_M \cdot \gamma_{DB}$;

γ_M —— Partial safety factor considering the material, geometric, and strength uncertainties, $\gamma_M = 1.1$;

γ_{DB} —— Partial safety factor considering the double bottom bending effects, in the hogging condition, $\gamma_{DB} = 1.0$ for the local model is applied with seawater pressure, otherwise, $\gamma_{DB} = 1.1$; in the sagging condition, $\gamma_{DB} = 1.0$.

3.3 Hull girder residual strength criterion

3.3.1 The residual ultimate capacity of any cross-section of the hull girder after collision/grounding damage is to meet the following criteria:

$$\gamma_{SD} M_S + \gamma_{WD} M_W \leq \frac{M_{UD}}{\gamma_{RD}}$$

Where:

M_S —— Allowable hydrostatic bending moment for calculated cross-section of hull girders,

in kN-m, see 2.2.2, Chapter 2 of ISC Rules for Cruise Ships;

M_W ——Wave bending moment for calculated cross-section of hull girder, in kN-m, see 2.2.3, Chapter 2 of ISC Rules for Cruise Ship;

M_{UD} —— The residual ultimate capacity of the calculated cross-section of the hull girder after collision/grounding damage, in kN-m, it is to be calculated by deducting the structural members within the extent of damage according to the provisions of Chapter 2 of the Guidelines;

γ_{SD} —— Partial safety factor of hydrostatic bending moment after damage , $\gamma_{SD} = 1.1$;

γ_{WD} —— Partial safety factor of wave bending moment after damage, $\gamma_{WD} = 0.67$;

γ_{RD} —— Partial safety factor of hull girder residual ultimate capacity after collision/grounding damage, $\gamma_{RD} = 1.0$.

Appendix A Nonlinear Finite Element Methods and Usage Recommendations

A.1 General provisions

A.1.1 This Appendix introduces the relevant methods and terminology of nonlinear finite element calculation, and provides general guidance and usage recommendations.

A.1.2 With the development of finite element calculation software and numerical analysis techniques, there may be some non-linear finite element analysis techniques and methods not mentioned in this Appendix. The purpose of this Appendix is not to restrict users from using the new methods.

A.2 Iterative solution of load increment in nonlinear finite element

A.2.1 The main features of nonlinear analysis are that load increments and iterations are needed to obtain numerical solutions. In general, the load (including forced displacement load) is divided into a series of small increments. For each load increment, the solver starts to perform iterative solution. When the error of the solution is less than the set tolerance, the iteration is stopped, indicating that the solution of this load increment step is convergent, and the next load increment is executed until the calculation and solution of all load increment steps are completed.

A.2.2 The increment size of the load or time step has a significant influence on the efficiency and accuracy of the nonlinear computation. The increment size of the load and the number of iterations interact with each other. Generally, the larger the load increment, the more iterations are required. Too small a load increment will reduce the computational efficiency and will not significantly improve the computational accuracy. Due to the limited convergence radius of the iterative algorithm, too large a load increment may cause the solution to be unconverged. The main problem of nonlinear analysis is how to select the most effective method from the options of load increment and iteration.

A.2.3 The load increments in many commercial nonlinear finite element programs are automatically controlled by the software, and the user only needs to specify the size of the first load increment. For most nonlinear problems, using automatic load increments is sufficient. Manual load increment control is only used in very few cases where convergence cannot be achieved by any means.

A.3 Selection of iterative algorithms

A.3.1 Three commonly used algorithms for nonlinear problems are:

- (1) The Newton-Raphson (N-R) algorithm used for static or dynamic implicit analysis, see A.3.2;
- (2) The modified Newton-Raphson (Quasi N-R) algorithm, see A.3.3;
- (3) The arc length method applicable only to static analysis, see A.3.4.

A.3.2 The Newton-Raphson algorithm is the most popular iterative method in nonlinear finite elements, and this method has quadratic convergence. This algorithm updates the tangent stiffness at each iteration to minimize the residual as much as possible to ensure the rapid convergence of the solution.

A.3.3 The modified Newton-Raphson algorithm is similar to the Newton-Raphson algorithm, with the difference that an invariant tangential stiffness is used for all iterations within the load increment step. Hence, there is no need to recalculate the stiffness at each iteration, greatly reducing the computational workload. However, the modified N-R algorithm usually requires

more iterations to achieve the same accuracy as the N-R method, thereby offsetting the increased efficiency brought about by keeping the stiffness matrix unchanged.

A.3.4 The Newton's method is based on a given load increment, and a convergent solution is obtained through iterations. The arc length algorithm regards the load increment as an additional unknown when solving, and simultaneously solves the load and displacement. Since the load increment is determined by the balance solution of the system, this method can be used to solve the post-buckling limit strength problem of the structure.

A.3.5 For different types of analysis (static nonlinear or dynamic nonlinear analysis), load control types (force or forced displacement load), and the expected nonlinear response of the structure, an appropriate iterative method needs to be selected. The general recommendations are as follows:

(1) When using load-controlled static analysis, the Newton method usually cannot find the highest point in the load-displacement curve, because this algorithm relies on the tangent stiffness. At the highest point of the curve, the tangential stiffness of the system becomes zero or negative. At this time, the structure begins to release energy to maintain balance, while the load is still increasing, and the system interrupts the calculation because it cannot find the corresponding solution.

(2) When using displacement-controlled static analysis, the Newton method can track the highest point in the load-displacement curve and the solutions after that.

(3) The arc length method is suitable for static analysis of highly nonlinear unstable problems. Since the load and displacement are solved simultaneously, this method can track the entire load-displacement curve. It is to be noted that if the load includes forced displacement, the arc length method is not applicable.

A.4 Selection of nonlinear analysis types

A.4.1 For the calculation of the ultimate capacity of hull girder, the following types of nonlinear analysis can be adopted:

(1) Static analysis, see A.4.2;

(2) Quasi-static analysis, see A.4.3-A.4.5.

A.4.2 In the process of static analysis, the load or displacement is gradually applied, and for each load increment, an iterative algorithm is used to find the solution of the static equilibrium equation. static analysis does not consider the inertial effect.

A.4.3 Quasi-static analysis is a kind of dynamic analysis, which is especially suitable for use when static analysis cannot converge. Its purpose is to eliminate the unstable behavior of the structure by introducing the minimized inertial effect to obtain the extreme value and the descending section of the load-displacement curve. Due to the introduction of the inertial effect in this method, for the calculation of the hull girder ultimate capacity, it is necessary to minimize the influence of the inertial load as much as possible. Usually, the following methods are used to reduce the inertial effect of the system:

(1) Minimize the rate of load change as much as possible in the initial and final stages of the calculation. A smooth step function can be used to apply the load or displacement. The smooth step function gradually increases the rate of load change from zero to the maximum at the initial stage and gradually reduces the rate of load change to zero at the final stage of the analysis. A typical load smoothing step function can be taken as the following form, as shown in Figure A.4.3.

$$f(t) = 0.5[\sin(\pi t - \pi/2) + 1]$$

(2) Since the inertial effect is proportional to the mass of the structure, the influence of the inertial effect on the system can be reduced by changing the material density. It is generally recommended

to reduce the material density by an order of magnitude. As the mass of the unit decreases, the critical time increment of explicit analysis also decreases, which will increase the solution time of explicit analysis, but it will not have an impact on implicit analysis.

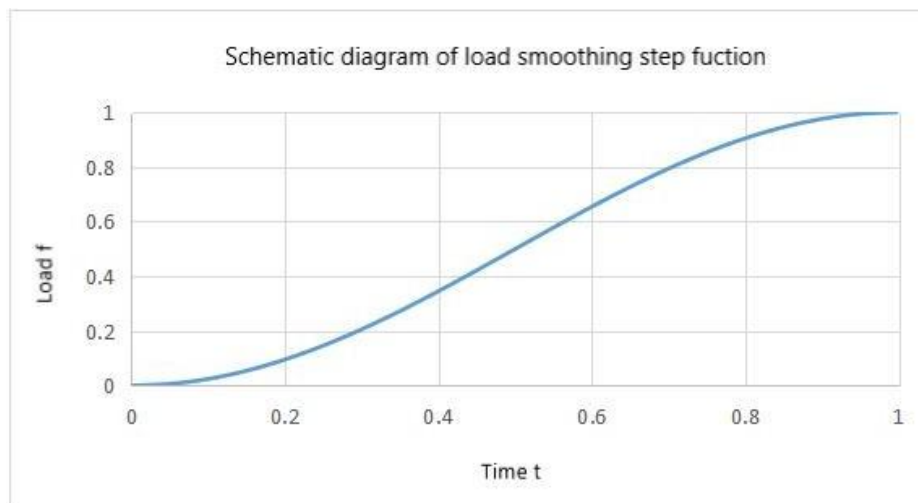

Figure A.4.3 Schematic diagram of load smoothing step function

A.4.4 The rationality of using the quasi-static method for ultimate strength analysis is to be verified by comparing the kinetic energy of the system and the internal energy. In general, it is to ensure that the kinetic energy is always less than 5% of the strain energy.

A.4.5 In addition to checking the proportion of the kinetic energy and internal strain energy of the system, the rationality and accuracy of the quasi-static analysis can also be further verified by checking whether the slope of the linear part of the load-displacement curve is consistent with the result of the linear static analysis.

A.5 Load cases and restart analysis technologies

A.5.1 In linear analysis, different load cases are independent of each other, representing different load conditions. In nonlinear analysis, load cases are interrelated. The final geometric deformation and material strain results of the previous load case are the initial conditions of the next load case. Therefore, the structural response, ultimate capacity, and collapse sequence in nonlinear analysis depend on the load path or loading sequence.

A.5.2 For the calculation and assessment of the hull girder ultimate capacity, it is recommended to apply the load on the structure in the order in which it actually occurs in the structure, i.e.: first apply the static load (including local pressure load, gravity load and static load of the hull girder), and then gradually apply the dynamic environmental load until the target is reached or the structure collapses.

A.5.3 Because nonlinear analysis is related to the load path, if it is necessary to modify the calculation parameters of a certain load case during the calculation process or if the calculation is interrupted due to an accident, it is necessary to recalculate all load cases, which is very time-consuming. The restart analysis technologies can save the completed calculation results on an external medium, and subsequent analysis can be continued based on the existing analysis results (different load cases, load increments and convergence parameters, etc.). For calculation models with a relatively long calculation time, it is recommended to set a restart.